

RAVAS-1100

Transpalet cu cantar cu functii de baza



BENEFICII:

- Cel mai vandut transpalet RAVAS
- Rezistenta la socuri si vibratii
- Etanseitate la apa pentru utilizare in mediu extern
- Consum redus de energie
- Destinat la receptii de marfa si cantariri pentru livrari

Calitate de top

Pentru uz industrial

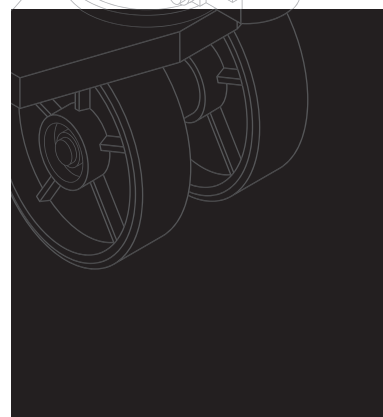

RAVAS

FUNCTII

- Corectie automata si manuala la 0
- Cantarire bruta/neta
- Totalizare cu alocare numar cantarire
- Afisare mesaje eroare pe ecran
- Oprire automata dupa 3 minute de neutilizare
- Avertizare baterie descarcata

SPECIFICATII STANDARD

- Capacitate de cantarire 2.000 kg
- Diviziune 1 kg
- Toleranta maxima 0,1% din greutatea ridicata
- Ecran LCD
- Tastatura 3 taste operare, tasta pornit/oprit
- Clasa de protectie IP65
- Roti directie cauciuc
- Roti sarcina poliuretan, tandem
- Culoare rosu (RAL 3000), vopsit epoxidic
- Greutate proprie 104 kg
- Alimentare 4 baterii AA 1,5V
- Autonomie la 5 utilizari zilnice, autonomie de pana la un an
- Pompa ridicare rapida

DIMENSIUNI IN MM

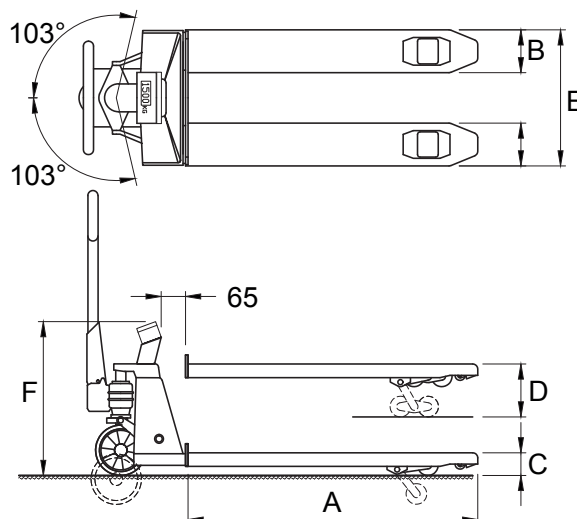

A	Lungimea furcilor	1150
B	Latimea furcilor	180
C	Inaltimea minima a furcilor	85
D	Inaltimea maxima a furcilor	200
E	Latimea ansamblului de furci	555
F	Inaltimea deasupra indicatorului	600



ISO 9001:2008
ISO 14001:2004
www.tuv.com
ID: 000057200

OPTIUNI PREMIUM*

- Imprimanta termica incorporata
- Omologare tranzactii comerciale cu pana la 2000 diviziuni, OIML III

OPTIUNI*

- Multidiviziune 0,5/1kg
- Transpalet din otel inox
- Dimensiuni variate ale furcilor
- Frana de picior

* Utilizarea optiunilor ar putea modifica specificatiile mentionate

DATA SPEED SRL

Str. Corneliu Coposu Nr. 103,
Cluj-Napoca, RO-400235, Jud. Cluj, Romania
T. +40 264 566 473, F. +40 364 815 440
office@cantare.com.ro, www.cantare.com.ro

